

Clamps, Grabs & Tongs



The Caldwell Group • 800-628-4263 • www.caldwellinc.com

Rig-Master® Section
2011-2013 Master Catalog

Model ST - Slab Tongs



IN-STOCK PROGRAM

PRODUCT FEATURES:

- Designed for lifting dry slabs of concrete, stone, or metal that must be protected from scratching or marring.
- Use in construction work to position slabs.
- The curved pads give proper contact for gripping smooth surfaces and handling a large range of sizes.
- Polyurethane gripping surfaces are standard.
- A manual latch is standard and locks the tong arms for easy placement on the load.
- Complies with ASME standards.

3.25 Ton SHACKLE

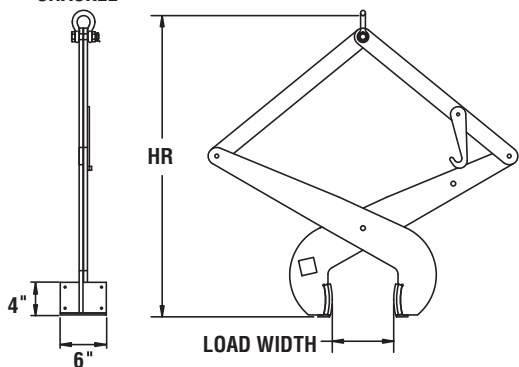

SPECIFICATIONS

Model Number	Rated Capacity (lbs.)	Load Width (in.) Min. - Max.	HR Headroom (in.) Min. - Max.	Weight (lbs.)
71-0	1000	1 - 6	31.30 - 39.58	65
71-1	1000	6 - 10	35.06 - 43.00	75
71-2	1500	8 - 12	29.18 - 38.06	85
71-3	1500	10 - 14	31.43 - 42.00	145
71-4	1500	14 - 18	41.38 - 51.25	145
71-5	1500	18 - 22	48.90 - 60.00	150

Model 172 - Concrete Pressure Tong with Urethane Pads



NEW

PRODUCT FEATURES:

- Designed for handling cured concrete products.
- Automatically adjusts to the load size.
- Easy to release manual latch.
- Pivoting pads align with load surface for proper contact.
- Polyurethane pads grip surface without damage.
- Complies with ASME standards.

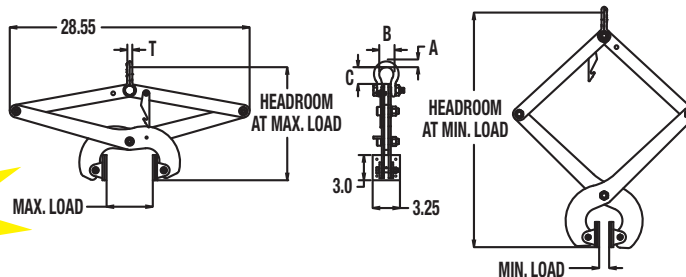

NOTE: Dimensions shown in inches.

SPECIFICATIONS

Model No	Rated Cap. (lbs.)	Dimensions (inches)							Weight (lbs.)
		Load Width Min - Max	Overall Width Min - Max	HR Headroom Min - Max	Bail				
					A	B	C	T	
172-1/4	550	1-3/16 - 5-1/2	21.8 - 28.8	13.5 - 29.5	11/16	1-11/16	2	11/16	25
172-1/2	1100	1-3/16 - 5-1/2	21.8 - 28.8	13.5 - 29.5	3/4	2	3-3/8	5/8	43

IN-STOCK PROGRAM